

VB400

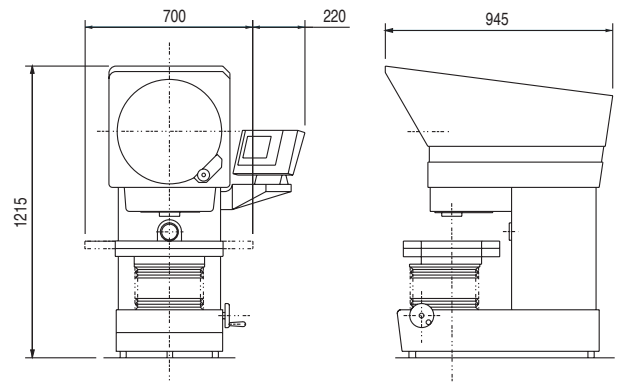

Vertical Bench Top Optical Projector

Having a large measuring capacity, the VB400 has the versatility to be at home in many differing working environments: ideal for high volume or low batch production or on routine component sampling, perfect for the general purpose tool room.

In fact the VB400 can be found wherever there is the need to verify and measure complex shapes, hole patterns etc., and where accuracy, ease of use and speed are of the essence.

Designed to be highly customised, you are assured of a projector configured to match your exact measuring requirements.

- ▶ Rigid all metal construction.
- ▶ Fully usable 400mm (16") diameter vertically mounted screen, with integral hood.
- ▶ Choice of standard or extra large workstage.
- ▶ Quick release table drive mechanism, for rapid table positioning.
- ▶ Motorised or CNC workstage options.
- ▶ Fast traverse, quick release mechanism on X and Y axis
- ▶ Available with the full range of Quadra-Chek readout systems.
- ▶ Electronic digital protractor.
- ▶ On axis and twin arm fibre optic surface illumination options available.
- ▶ Comprehensive range of multi-element precision ground lenses.
- ▶ Large range of accessories available.

Technical Specification

Starrett®

Screen Diameter

400mm (16") with precision cross lines, calibration markings and overlay clips.

Workstage

Top plate - 400 x 230mm (16 x 9").
Glass insert - 240 x 140mm (9.25 x 5.5").
Measuring Travel - 200mm x 100mm (8 x 4").

Focus

100mm (4").

Workstage Capacity

10kg (22lb) maximum.
(Evenly distributed).

Illumination

Profile - Fan cooled, halogen, switchable high/low intensity with yellow/green filter.

Surface - On axis and twin arm fibre optic options.

Measurement/display systems

Linear - Heidenhain scales (0.001mm resolution).
Simple DRO or Quadra-Chek readout systems with edge sensing option.

Angle - Digital protractor (1 minute resolution).
Quadra-Chek Q-Axis

Lenses

x10, x20, x25, x 31¹/₄, x50, x100.

Power Supply

110/120/230/240/250V.AC 50/60Hz.
Consumption 5A.

Visit our Web-Site at www.starrett-precision.co.uk

VB400 Specification:	SR121	SR221	SR221e	SR515	SR515 CNC
Rigid steel body	●	●	●	●	●
Standard workstage 200 x 100mm travel	●	●	●	●	●
Extended workstage 250 x 150mm travel	○	○	○	○	○
Anti-corrosion nickel plated workstage top					
Rotary screen & clips	●	●	●	●	●
Handwheel X and Y drive control	●	●	●	●	
Motorised joystick control	○	○	○	○	
CNC control					●
Angular digital protractor	●	●	●	●	●
Angular digital measurement in QC DRO					
X-Y axis only digital readout	●				
Geometric function digital readout		●	●		
Computer with geometric s/ware readout.				●	●
On screen edge sensing			●	●	●
Internal edge sensor					
Single interchangeable lens mount	●	●	●	●	●
Dual lens slide					
Multi lens turret	○	○	○	○	○
Fibre optic surface illumination	○	○	○	○	○
On-axis surface illumination	○	○	○	○	○
Single condenser					
Dual condenser slide	●	●	●	●	●
Multi condenser turret					
Yellow/green light filter	●	●	●	●	●
Available lenses (See guide below)	○	○	○	○	○
X5 magnification lens					
X31¼ magnification lens option	○	○	○	○	○
Standard or deluxe support cabinet	○	○	○	○	○
Canopy and curtains	○	○	○	○	○
Work holding accessories	○	○	○	○	○
Magnification checking graticule	○	○	○	○	○
OV² Optical video adaptor					
Screen overlay templates	○	○	○	○	○

Standard ● Optional ○

Guide to Maximum Component Size (mm)						
Magnification	X5	X10	X20	X25	X50	X100
Field of View	N/A	40	20	16	8	4
Working Distance	N/A	80	76	62	50	41
Max Work Diameter	Half Field	N/A	140	140	140	106
	Full Field	N/A	140	140	140	98
Projected Image	Fully Reversed					

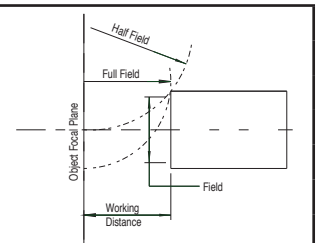

Terminology:

- Working Distance:** Is the distance between the objective lens and the component when the component is in focus.
- Field of View (FOV):** Is the viewing area of the component. A 30mm FOV using a 10x lens would produce a screen image of 300mm.
- Half Field View:** Is the maximum size a component can be projected to the centre of the screen before colliding with the lens.
- Full Field View:** Is the maximum size a component can be projected over the full screen before colliding with the lens.
- Projected Image:** Is how a component is projected onto the screen in relation to its placement on the workstage.